

Endüstriyel Kalıp / Wall Formwork

Standart Paneller /

SRZ 320
325 cm

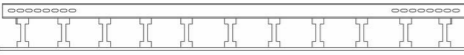

SRZ 295
300 cm

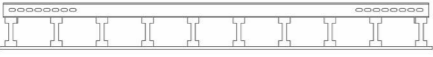

SRZ 270
275 cm



SRZ 245
250 cm

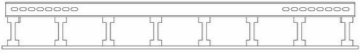

SRZ 220
225 cm



SRZ 195
200 cm

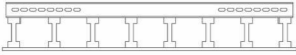

SRZ 170
175 cm

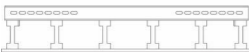

SRZ 145
150 cm

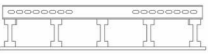

SRZ 120
125 cm

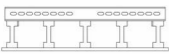

SRZ 95
100 cm



SRZ 70
75 cm



VSRZ 90
95/50 cm

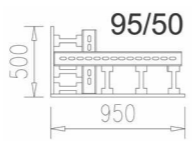

SRZ 145
145 cm

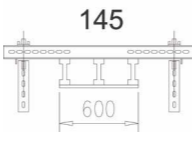

SRZ 120
120 cm

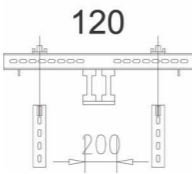

Elit Proje - Hızlı Tren OHL



Incekaya İnşaat - ASKI

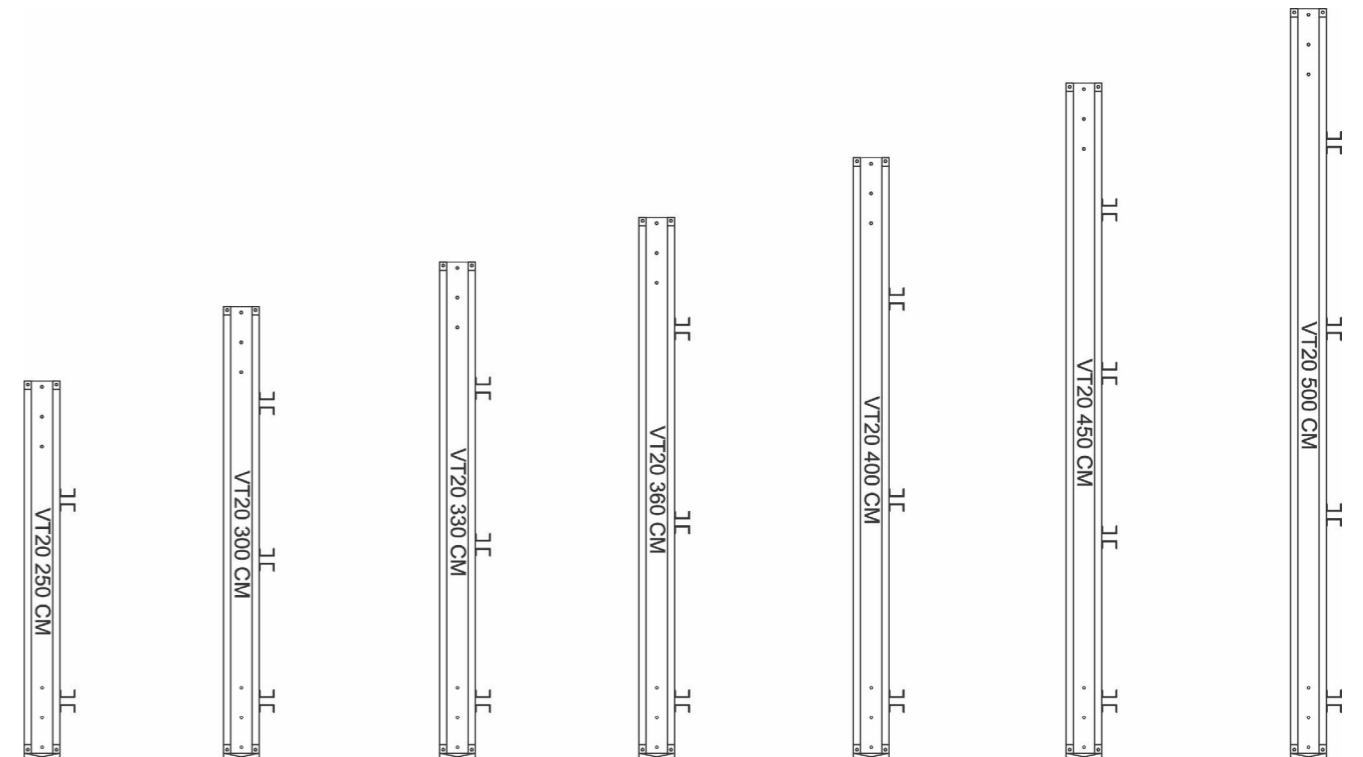

Endüstriyel Kalıp / Wall Formwork



Mertim İnşaat - Kırıkkale

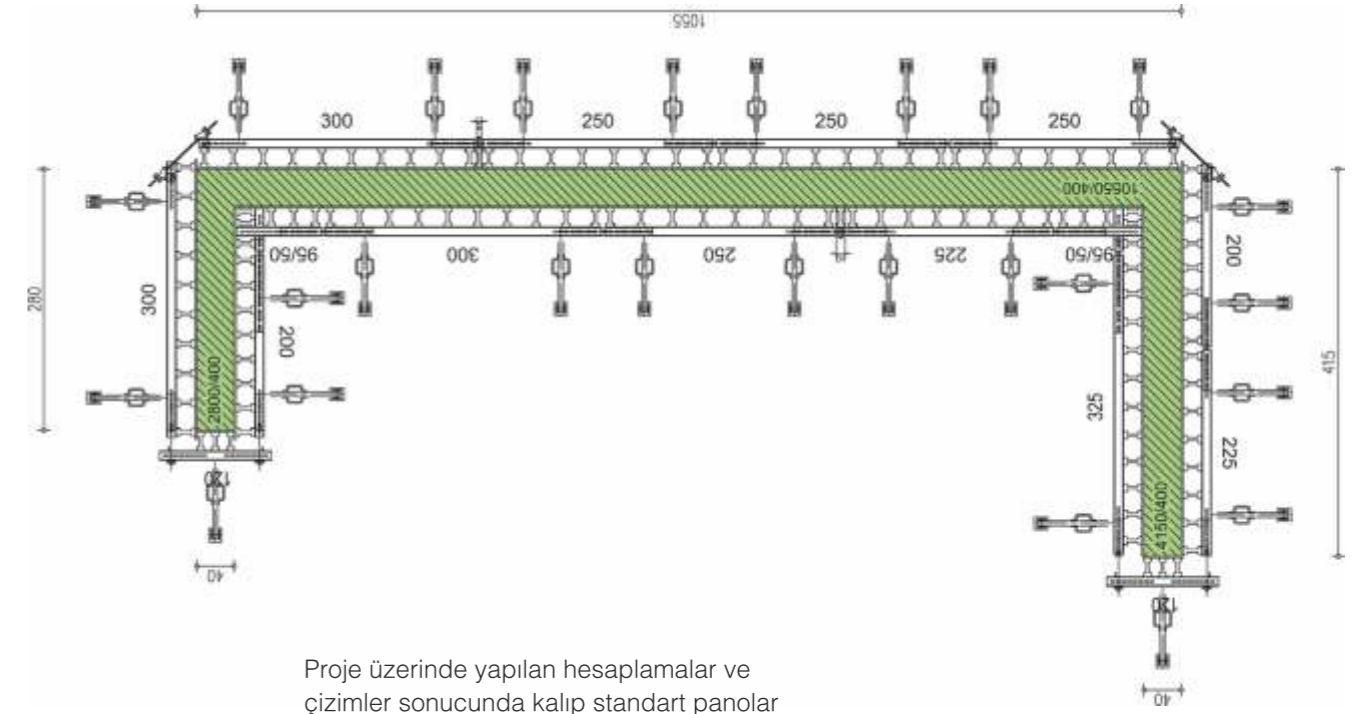

Proje üzerinde yapılan hesaplamalar ve çizimler sonucunda kalıp standart panolar haline getirilip hazırlanır.

Birbiri ile birleştirilebilen panolar vinç ya da hiyap türü kaldırıcılarla kolayca yer değiştirilip beton dökümü aşamasına gelir.

The calculations and drawings on the project results into the pattern, whether the standard panels are prepared.

Panels can be combined with other types of cranes or hoists hiyap easily come to the stage where the concrete is changed.



Kalandap / Özdoğanlar İnşaat - Balıkesir



Mertim İnşaat - Kırıkkale

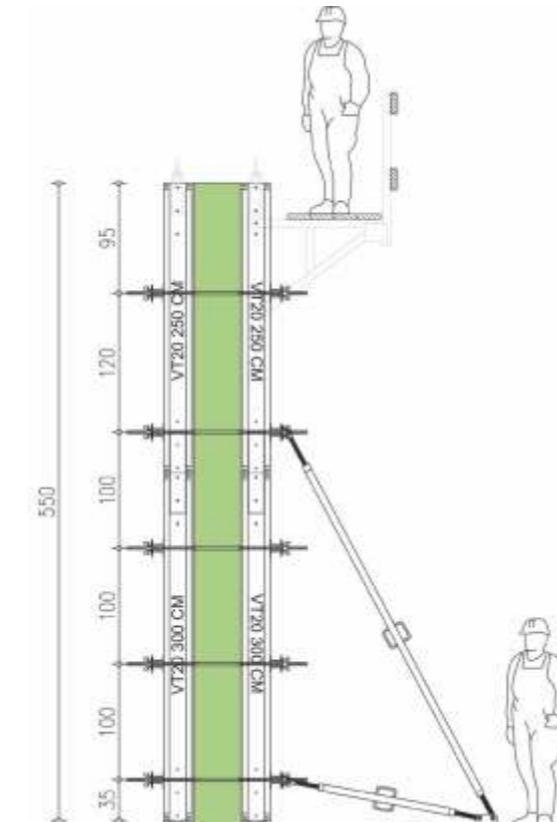

Kalemci Yapı / Bandırma - EnerjiSA Şantiyesi

Endüstriyel Kalıp / Wall Formwork



1 Pano montajı için önceden bir platform oluşturmak gerekir. VT20 ahşap kirişlerin ve çelik perde kuşakların birbirine dik ve kendi aralarında hizada olması çok önemlidir. Bunu sağlamak için platformun üzerinde gönye oluşturulur. İlk olarak çelik perde kuşakları bu gönyelere, projedeki ölçüler dahilinde yerleştirilir.

Before the board to create a platform for the assembly is required. VT20 wooden beams and steel curtain generations must be aligned perpendicular to each other and among themselves is very important. To ensure this rule is created on the platform. Squares to this first generation of the steel curtain, the project is placed within the dimensions.

Kenar VT20 ahşap kirişler çelik perde kuşakların üzerindeki lamalara civatalanarak sabitlenir.

VT20 edge over generations support wood beams with steel curtain is fixed.



2 Daha sonra aradaki VT20 ahşap kirişler projedeki ölçülere göre yerleştirilerek kancalar yardımıyla monte edilir. VT20 ahşap kirişlerin üst ve alt kotunun aynı hizada olması önemlidir. Bunun için oluşturulacak panonun altına hizalama gönyesi çakılır.

Then in between sizes according to VT20 wooden beams are placed on the project with the help of the hooks are mounted. VT20 wooden beams of the upper and lower level must be aligned is important. For this alignment will be created under the rule of the board is struck.



Vinç askı takımları VT20 ahşap kirişlere monte edilir ve daha sonra plywood ile VT20 ahşap kirişler ağaç vidaları ile sabitlenir.

Cranes are mounted on wooden beams suspended teams VT20 and VT20 plywood and then fixed with wooden beams, wood screws.



4



5 Ankraj milleri için plywood üzerinde delikler işaretlenerek delinir. Son olarak vinç vasıtasıyla oluşturulan pano kaldırılır. Bu kaldırma esnasında, vinç askı takımları arasına ilave ahşap kalas monte edilebilir. Bu ahşap kirişlere gelen yanal yüklerin karşılanmasına yardımcı olur.

Anchor shafts are drilled and marked holes on the plywood. Finally, the crane is removed through the panel created. During this removal, wood beams add to the winch strap can be mounted between the teams. Wooden beams, this helps against lateral loads.



Endüstriyel Kalıp / Wall Formwork



NY Yılmaz İnşaat / Citroen Plaza - Ankara



Kalandap / Özdoğanlar İnşaat - Balıkesir



Saatçi İnşaat - Cumhurbaşkanlığı Senfoni Orkestrası



NY Yılmaz İnşaat / Citroen Plaza - Ankara



Mertim İnşaat - Gaziantep

Endüstriyel Kalıp / Wall Formwork

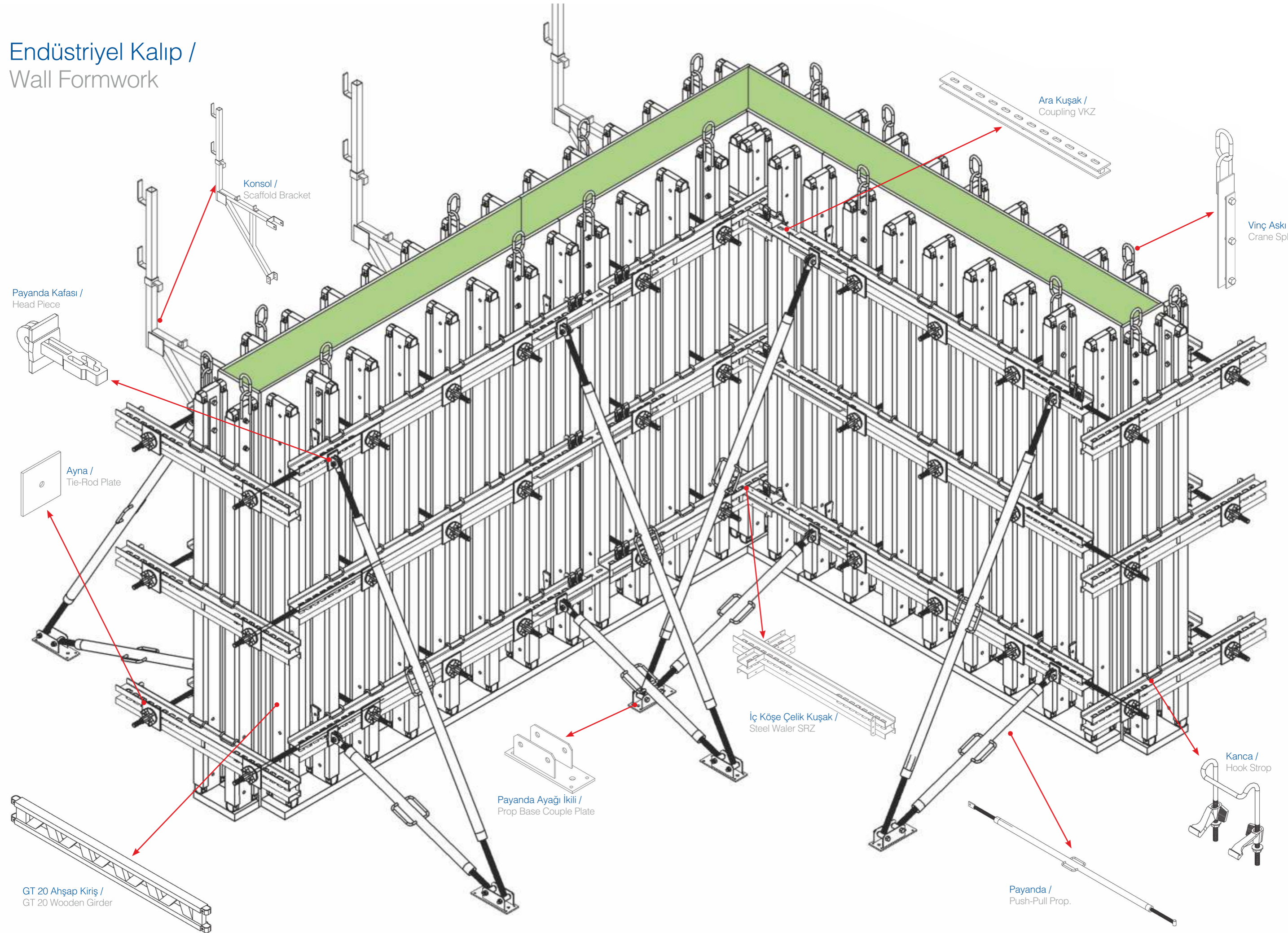

Konsol /
Scaffold Bracket

Payanda Kafası /
Head Piece

Ara Kuşak /
Coupling VKZ

Vinç Askı Takımı /
Crane Splice

Ayna /
Tie-Rod Plate

İç Köşe Çelik Kuşak /
Steel Waler SRZ

Payanda Ayağı İkili /
Prop Base Couple Plate

Kanca /
Hook Strop

GT 20 Ahşap Kiriş /
GT 20 Wooden Girder

Payanda /
Push-Pull Prop.

Endüstriyel Kalıp / Wall Formwork

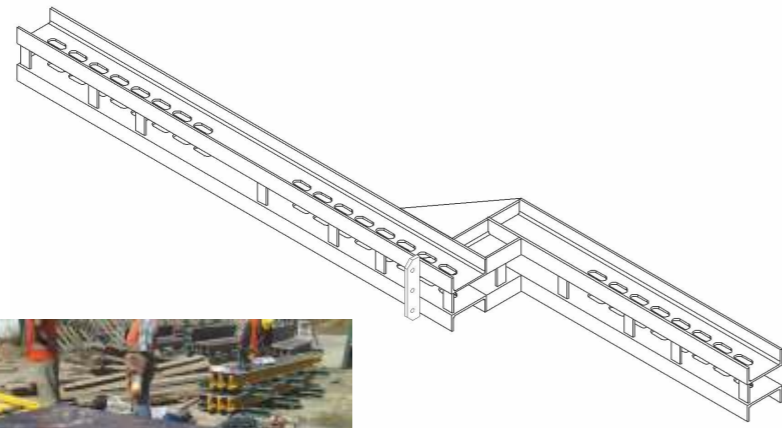
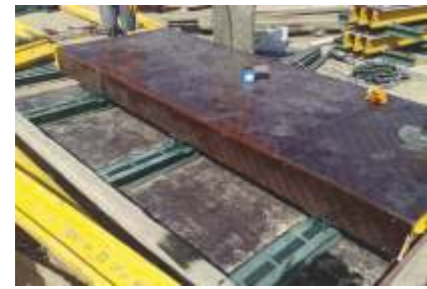
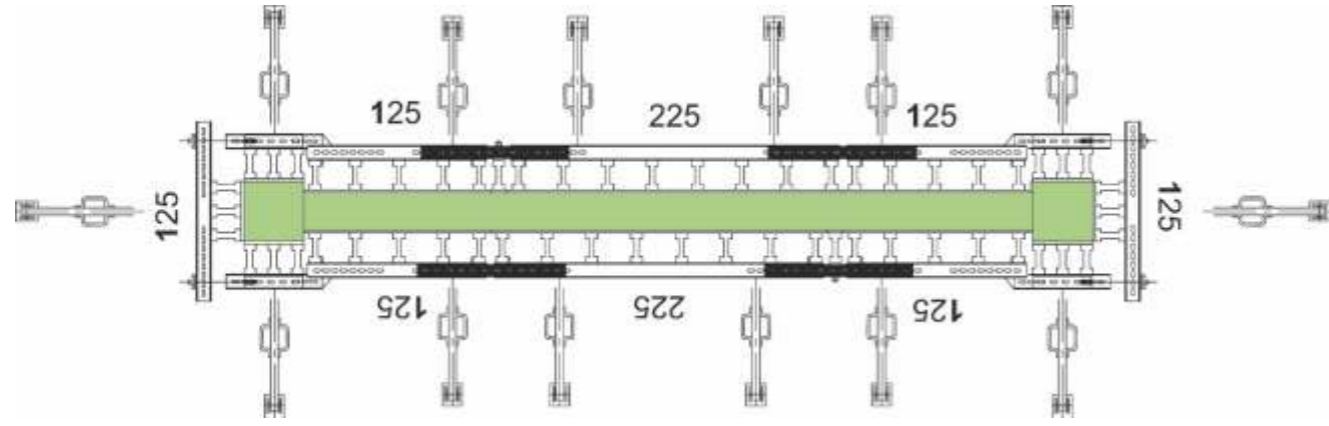

Teknik Özellikler / Technical Data



	Referans No. Reference No.	Boy (mt) Length (mt)	Ağırlık (kg) Weight (kg)		Referans No. Reference No.	Boy (mt) Length (mt)	Ağırlık (kg) Weight (kg)	
GT 20 Ahşap Kiriş / GT 20 Wooden Girder	E 100	1.20	4.80		Çelik Kuşak / Steel Waler SRZ	E 130	0.70	15.00
	E 101	1.50	6.00			E 131	0.95	21.00
	E 102	1.80	7.20			E 132	1.20	25.40
	E 103	2.10	8.40			E 133	1.45	30.70
	E 104	2.40	9.60			E 134	1.70	36.00
	E 105	2.70	10.80			E 135	1.85	38.70
	E 106	3.00	12.00			E 136	1.95	41.30
	E 107	3.30	13.20			E 137	2.20	46.60
	E 108	3.60	14.20			E 138	2.45	52.00
	E 109	3.90	17.60			E 139	2.70	57.20
				E 140	2.95	62.50		
				E 141	3.20	68.00		
				E 142	3.45	73.00		
GT 24 Ahşap Kiriş / GT 24 Wooden Girder	E 110	1.20	7.10		İç Köşe Çelik Kuşak / Steel Waler SRZ	E 143	0.70	23.00
	E 111	1.50	8.90			E 144	0.95	27.70
	E 112	1.80	10.60			E 145	1.20	32.10
	E 113	2.10	12.40			E 146	1.45	37.40
	E 114	2.40	14.20			E 147	1.70	42.70
	E 115	2.70	15.90			E 148	1.85	45.40
	E 116	3.00	17.70			E 149	1.95	48.00
	E 117	3.30	19.50			E 150	2.20	53.30
	E 118	3.60	21.20			E 151	2.45	58.70
	E 119	3.90	22.00			E 152	2.70	63.90
				E 153	2.95	69.20		
				E 154	3.20	74.70		
				E 155	3.45	79.36		
VT 20 Ahşap Kiriş / VT 20 Wooden Girder	E 120	1.20	7.20		Özel Köşe Kuşak / Special Corner Steel Waler	E 156	*	21.00
	E 121	1.50	9.00					
	E 122	1.80	10.80					
	E 123	2.10	12.60					
	E 124	2.40	14.40					
	E 125	2.70	16.20					
	E 126	3.00	18.00					
	E 127	3.30	19.80					
	E 128	3.60	21.60					
	E 129	3.90	23.40					

* İşaretili ürünlerin ölçüleri değişkendir.

Endüstriyel Kalıp Teknik Özellikler /

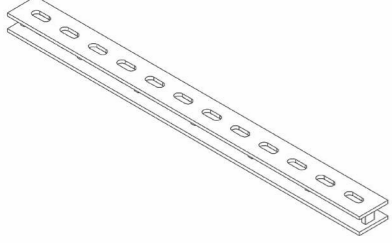
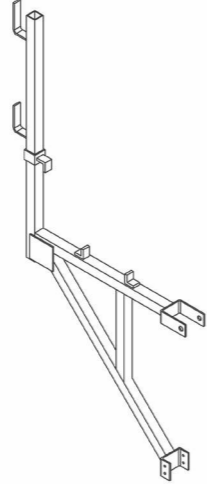
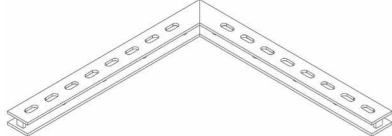
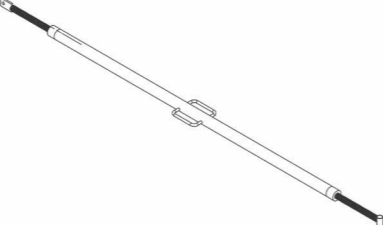
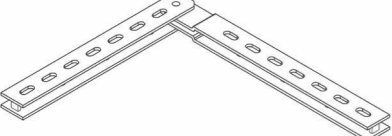
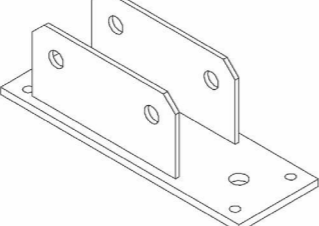

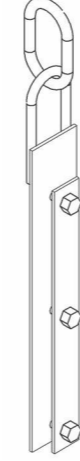
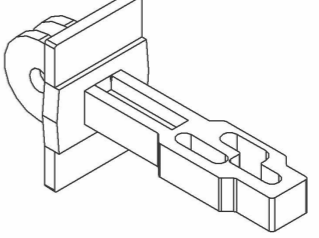
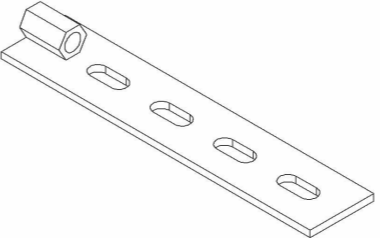
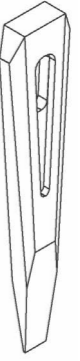
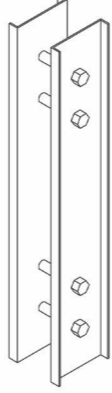

Wall Formwork Technical Data

	Referans No. Reference No.	Boy (mt) Length (mt)	Ağırlık (kg) Weight (kg)		Referans No. Reference No.	Boy (mt) Length (mt)	Ağırlık (kg) Weight (kg)
Ara Kuşak / Coupling VKZ	E 157 E 158 E 159	0.99 1.47 2.11	9.00 13.20 19.00	Konsol / Scaffold Bracket	E 164 E 165	0.70 1.00	11.00 13.40
							
Köşe Ara Kuşak / Corner Coupling EKZ	E 160 E 161	76/76 95/43	12.10 13.40	Payanda / Push-Pull Prop.	E 166 E 167 E 168 E 169 E 170 E 171 E 172 E 173 E 174	110/200 210/300 310/400 410/500 510/600 610/700 710/800 810/900 910/1000	14.00 17.50 21.50 30.20 37.00 60.00 75.00 90.00 110.00
							
Köşe Mafsallı Ara Kuşak / Corner Coupling GKZ	E 162 E 163	60/60 76/76	11.40 14.20	Payanda Ayağı İkili / Prop Base Couple Plate	E 175	-	4.50
							

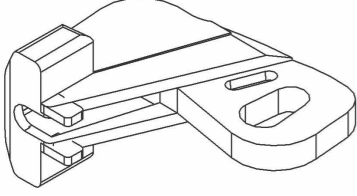
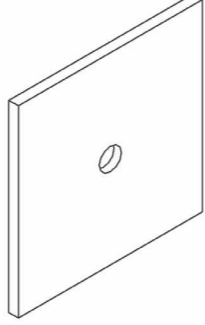
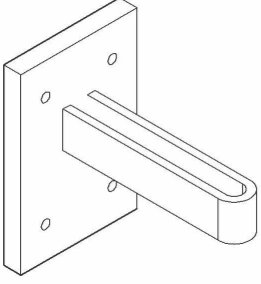

	Referans No. Reference No.	Boy (mt) Length (mt)	Ağırlık (kg) Weight (kg)		Referans No. Reference No.	Boy (mt) Length (mt)	Ağırlık (kg) Weight (kg)
Vinç Askı Takımı / Crane Splice	E 176	-	4.20	Payanda Kafası / Head Piece	E 179	-	2.30
							
Sonlandırıcı / Stopend Tie	E 177	-	5.50	Döküm Kafa / Wedge KZ	E 180	-	0.80
							
Ahşap Kiriş Uzatma / Extension Splice	E 178	-	5.50	Sac Kama / Wedge K	E 181	-	0.30
							

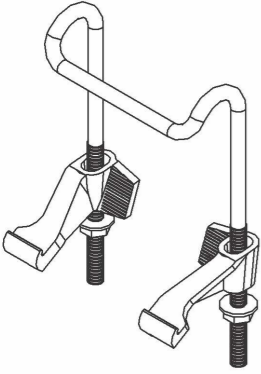
Endüstriyel Kalıp Teknik Özellikler /

Wall Formwork Technical Data

	Referans No. Reference No.	Boy (mt) Length (mt)	Ağırlık (kg) Weight (kg)		Referans No. Reference No.	Boy (mt) Length (mt)	Ağırlık (kg) Weight (kg)
Köşe Boynu / Corner Clamp Kdp	E 182	-	2.60	Ayna / Tie-Rod Plate	E 185 E 186	10/15 15/15	1.00 1.15
							
Yaprak / Coupling Plate	E 183	-	1.40	Yaprak Kaması / Coupling Plate Wedge	E 187	-	0.40
							
Kanca / Hook Strop	E 184	-	1.10	Tie-Rod / Tie-Rod	E 188	*	1.50
							

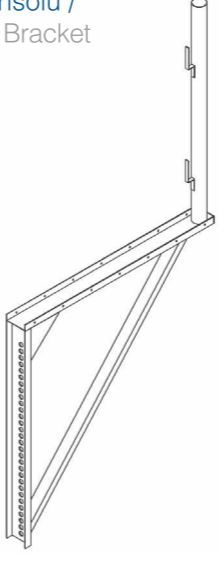
* İşaretili ürünlerin ölçüleri değişkendir.

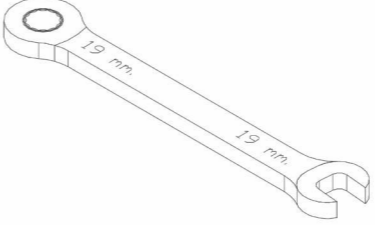
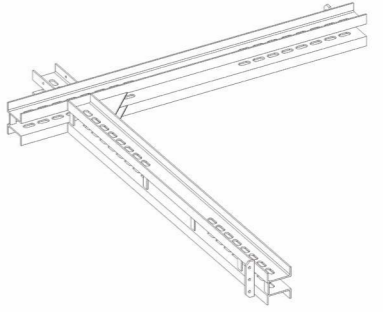
	Referans No. Reference No.	Boy (mt) Length (mt)	Ağırlık (kg) Weight (kg)		Referans No. Reference No.	Boy (mt) Length (mt)	Ağırlık (kg) Weight (kg)
Bina Konsolu / Scaffold Bracket	E 189 E 190 E 191 E 192	1.00 1.50 2.00 2.50	30.00 42.50 57.00 71.00	Ahşap Vidası / Screw	E 195 E 196 E 197	6x40 6x60 6x80	0.005 0.008 0.010
							
Anahtar / Ratchet Spanner	E 193	0.019	1.00	Köşe Perde Kuşağı / Corner Waler	E 198	1.00x1.00	42.00
							
Tie-Rod Somunu / Wing Nut	E 194	-	0.45				
